

EGG INDUSTRY AUTOMATED SOLUTIONS

IMS
GROUP
USA
**INNOVATIVE
MACHINERY
SOLUTIONS**

Alpha 60 Automatic Sleeving Machine

Designed specifically for egg packaging lines, this machine can process various sizes of both pulp and plastic egg packs, automatically wrapping and sealing cartons.



➤ Packs Infeed

- 43.200 eggs/hour, 60 eggs packs/minute
- Brushless motor for precise spacing

➤ Multiple formats

- 1 x 10
- 2 x 6
- 3 x 4

➤ Raw materials

- Plastic
- Pulp

➤ HMI

- User-friendly programming with HMI
- Remote support via online connection

➤ Sleeves magazine

- Automatic picking system with suction cups
- Missing sleeve detection

➤ Main chain with supports

- Easy maintenance and cleaning access

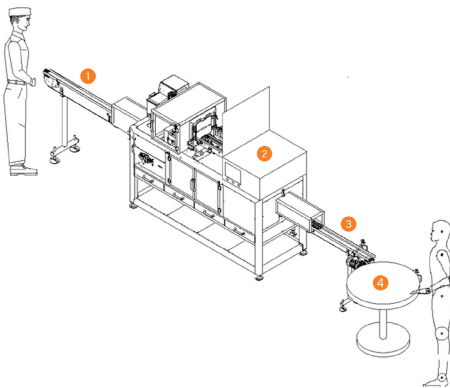

- ➊ INFEED CONVEYOR
- ➋ ALPHA 60 SLEEVING MACHINE
- ➌ OUTFEED CONVEYOR
- ➍ ACCUMULATION TABLE Ø1400mm



EGG INDUSTRY AUTOMATED SOLUTIONS



Automatic Case Packer for Egg Packs

- Robotic solution for high demand
- Built-in case erector and closing unit
- Compact design for limited space



Scara Palletizer on Rails

- Modular in product handling and pallet pattern
- Multi pallet stations
- User friendly operation

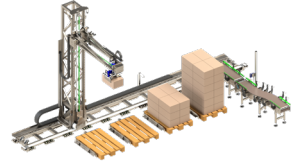

Robotic Palletizer/Depalletizer

- Suitable for eggs trays, both plastic and paper
- Eliminates manual loading work
- Reliable and low maintenance

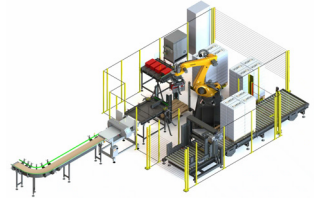

Complete End-Of-Line Solutions

As end-of-line automation experts, IMS offers turnkey solutions that virtually eliminate manual tasks, automating time consuming and labor-intensive activities.

Service

We put the customer at the center of everything we do, offering innovative solutions and unparalleled service every step of the way.



Remote Support



Maintenance + Service



Spare Parts



Training



+1 (616) 942-5500



info@imgroupusa.net



www.imgroupusa.net



2900 Charlevoix Dr. SE, Suite 110
Grand Rapids, MI 49546

